

$-121.0^{\circ}$ . Phosphorus pentoxide was then added directly to the liquid and again a freezing point of  $-120.6^{\circ}$  was observed.

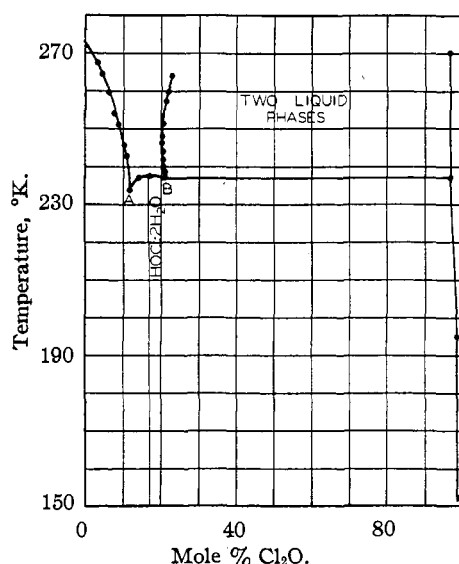

Fig. 1.—Temperature-concentration diagram for the system chlorine monoxide-water. Several experimentally determined points between A and B have been omitted on the graph (see Table I for data).

Due to the discrepancy between this result and the value of  $-116^{\circ}$ , reported by Goodeve,<sup>1</sup> the thermocouple was recalibrated at the boiling point of oxygen. A fresh sample of chlorine monoxide, dried as before, was prepared. In order to free the chlorine monoxide from dissolved

air and chlorine, approximately one-fourth of the sample was distilled off at about  $-75^{\circ}$ . The freezing point then observed was  $-120.6^{\circ}$ . After removing a second portion of the chlorine monoxide in the same manner, the same freezing point was obtained. Addition of water gave the same depression of  $0.4^{\circ}$ , as previously found.

The temperature-concentration diagram for the system is shown in Fig. 1. Point B, at 20.7 mole % chlorine monoxide and  $236.8^{\circ}\text{K}$ ., is an invariant point representing equilibrium between two liquid phases, the solid phase and the gaseous phase. It is to be noted that solid HOCl is not obtained. A solution containing a sufficiently high concentration of chlorine monoxide to give the compound HOCl would separate into two liquid phases before freezing and give, as the solid phase, the hydrate,  $\text{HOCl}\cdot 2\text{H}_2\text{O}$ .

### Summary

The freezing point-composition diagram for the system chlorine monoxide-water has been studied over the entire range, and solubilities of chlorine monoxide in water and of water in chlorine monoxide have been measured. Chlorine monoxide and water are a pair of partially miscible liquids. The solid phase formed from solutions of concentration greater than 11.7 mole % chlorine monoxide has the composition  $\text{HOCl}\cdot 2\text{H}_2\text{O}$ .

SEATTLE, WASHINGTON RECEIVED FEBRUARY 20, 1940

[CONTRIBUTION FROM THE DEPARTMENT OF CHEMISTRY OF THE UNIVERSITY OF ROCHESTER]

## Photochemical Studies. XXX. The Fluorescence of Biacetyl. Some General Considerations Governing the Study of Fluorescence

BY F. C. HENRIQUES, JR., AND W. ALBERT NOYES, JR.

Recent studies of the fluorescence of acetone have shown that under some conditions a Stern-Volmer equation is at least approximately obeyed<sup>1</sup> but that if the intensity of the incident radiation is sufficiently high, noticeable increase of fluorescence with time is observed.<sup>2</sup> Moreover, the three intense bands of acetone fluorescence were shown to be identical with those of biacetyl. It also has been shown that the main portions of the fluorescences of acetaldehyde and of methyl ethyl ketone are identical with those of biacetyl

and of acetone.<sup>3</sup> It seems probable, therefore, that the fluorescing molecule is the same in all of these cases and that it is probably biacetyl.

Several questions still remain unanswered concerning the so-called fluorescence of acetone, particularly those having to do with the mechanism whereby the biacetyl molecule is excited when acetone is the absorber. It has seemed advisable, therefore, to investigate the effect of certain variables on the fluorescence of biacetyl. The fluorescence of this molecule has been investigated

(1) Fisk and Noyes, *J. Chem. Phys.*, **2**, 654 (1934).

(2) Matheson and Noyes, *THIS JOURNAL*, **60**, 1857 (1938).

(3) Matheson and Zabor, *J. Chem. Phys.*, **7**, 536 (1939).

from several angles by Almy and his co-workers.<sup>4,5,6,7</sup> Their conclusions may be summarized briefly as follows: (a) the spectrum of the fluorescence is independent of the exciting wave length (3650, 4047, 4358 Å.); (b) little or no quenching by biacetyl is observed when the exciting wave length is 4358 Å., *i. e.*, as the pressure is increased, the intensity of the fluorescence is proportional to the absorbed intensity; (c) the fluorescence is quenched by oxygen and (strongly) by iodine; (d) the mean lifetime of the excited biacetyl molecules as determined by various methods is quite long, probably longer than  $10^{-5}$  second; and (e) the quantum yield of fluorescence is quite low, being a maximum of about 0.03 fluorescence quantum per absorbed quantum at 3650 and 4358 Å.

In the present investigation a study of the effects of pressure, of temperature, of wave length, of intensity, and of added acetone on the fluorescence has been made. From this study certain seemingly valid conclusions can be drawn concerning the fate of the excited biacetyl molecules and the nature of upper electronic levels.

### I. Some General Considerations Governing Fluorescence Studies

In a recent article<sup>8</sup> several aspects of problems relating to fluorescence have been treated. It was emphasized that with increase in pressure of the absorbing gas, there is a volume redistribution of absorbed intensity which may lead to spurious results unless the absorption coefficient is very low. That is, the measuring device will intercept a fraction of the fluorescent quanta emitted from a certain volume within the cell. If this fraction varies as the distribution of absorbed intensity throughout this volume change, no valid conclusions can be drawn concerning quenching. This problem will be examined briefly.

Referring to Fig. 1 we will assume that the fluorescence is being studied with the aid of a T-shaped cell, that the  $x$ -axis is horizontal, the  $y$ -axis vertical, and the  $z$ -axis perpendicular to the plane of the paper. For the sake of simplification a parallel beam of radiation, the intensity of which is uniform throughout a cross section perpendicular to the  $x$ -axis, is assumed. The radius

of this cross section is  $y_1$ .  $I'_0$  is defined as the incident intensity at the center of the cell. It will be noted that this definition differs from that used later for  $I_0$ .

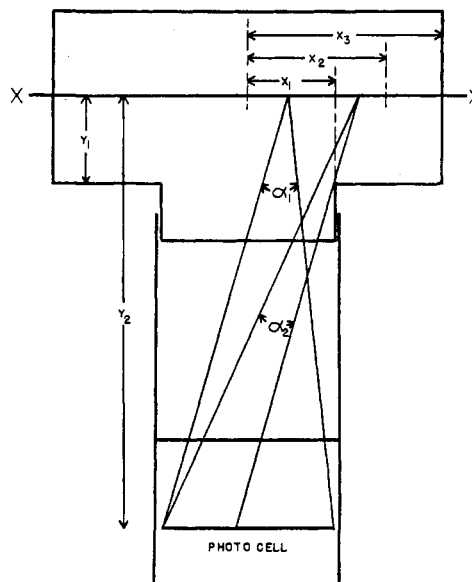

Fig. 1.

It is also evident that many complications are avoided if  $y_2$ , the distance from the axis of the main limb of the T to the light measuring device, is large compared to  $y_1$ , the radius of the tube making this limb. All radiation striking the walls is assumed to be absorbed.

Furthermore, the problem becomes very difficult to treat if the fluorescent intensity is not proportional to the absorbed intensity when all variables except the latter are kept constant. In the following paragraphs it is assumed that the intensity of the fluorescence from any volume element is proportional to the intensity absorbed when the pressure and the temperature are constant. The fluorescent radiation is assumed not to be absorbed by the gas, thus avoiding the serious complications due to radiation imprisonment.

It is obvious that the form of  $I_a$ , the intensity absorbed, must be

$$I_a = 2I'_0 \frac{\int \int \int_0^{x_3} \Pi_{xyz} bP \cosh(bPx) dx dy dz}{\int \int \int_{-x_3}^{x_3} \Pi_{xyz} dx dy dz} \quad (1)$$

where  $b$  is the absorption coefficient per unit distance along the  $x$ -axis and per unit pressure;  $P$  is the pressure.  $\Pi_{xyz}$  is the probability that

(4) Almy, Fuller and Kinzer, *Phys. Rev.*, **55**, 238 (1939).

(5) Almy and Fuller, *Trans. Illinois State Acad. Sci.*, **31**, 196 (1938).

(6) Fuller, Phillips and Almy, *J. Chem. Phys.*, **7**, 973 (1939).

(7) Almy, Fuller and Kinzer, *ibid.*, **8**, 37 (1940).

(8) Noyes and Henriques, *ibid.*, **7**, 767 (1939).

fluorescent light from the volume element  $dx dy dz$  will reach the light measuring device.

With the assumptions made above

$$\Pi_{xy} = \text{const. } \Pi_x \quad (2)$$

and hence  $I_a$  may be treated to a good first approximation as a function of  $x$  alone.

For  $0 \leq x \leq x_1$

$$\Pi_x = \alpha_1/2\pi \quad (3)$$

where to a good approximation

$$\alpha_1 = (2x_1/y_2) \left( 1 - \frac{x_1^2 + x^2}{y_1} \right) \quad (4)$$

For  $x_1 \leq x \leq x_2 = x_1(y_1 + y_2)/(y_2 - y_1)$

$$\Pi_x = \alpha_2/2\pi \quad (5)$$

where to a first order approximation

$$\alpha_2 = \frac{x_1(y_1 + y_2) - (y_2 - y_1)x}{y_1 y_2} \left( 1 - 2x_1^2/y_2^2 \right) \quad (6)$$

For  $x_2 \leq x \leq x_3$

$$\Pi_x = 0 \quad (7)$$

By integrating equation (1) after making the proper substitutions for  $\Pi_x$  one obtains

$$I_a = \frac{I'_0}{2\pi} \int_0^{x_3} \frac{dx}{\Pi_x} \left[ \frac{4x_1}{y_2^2} \left( x_1^2 + \frac{1}{b^2 P^2} \right) \sinh x_1 b P + \frac{y_2 - y_1}{y_1 y_2 b P} \left( 1 - \frac{2x_1^2}{y_2^2} \right) \cosh x_2 b P - \left( 1 + \frac{2x_1^2}{(y_2 - y_1)y_2} \right) \cosh x_1 b P \right] \quad (8)$$

Unless the absorption coefficient is extremely high, all but the first two terms in the expansion of the hyperbolic functions may be neglected. Upon integration of  $\int_0^{x_3} \Pi_x dx$  and substituting, one obtains

$$I_a = I'_0 b P \quad (9)$$

Equation (9) should be valid if the assumptions made above are obeyed and if the fraction of the incident radiation absorbed between  $-x_2$  and  $+x_2$  is not over about 0.4. For other cases the use of equation (8) would be necessary.

## II. Experimental

The biacetyl (Eastman Kodak Co.) was repeatedly fractionally distilled at low pressures. The acetone (Merck reagent) was dried with calcium chloride and distilled in the dark.

Monochromatic radiation of wave length 3650 Å. was obtained from a General Electric Vapor Lamp Co. high pressure mercury arc (Uviarc UA30A2) combined with Corning Violet Ultra Glass and a cupric ammonium sulfate filter. For 3130 Å. a silvered surface and a solution of nickel and cobalt sulfates were used. For 2537 Å. the same solutions plus a filter of gaseous chlorine were used.

A T-shaped cell of the type previously used<sup>3</sup> was thermostated by a water jacket so that the temperature could be kept constant to 0.5°. The fluorescent radiation was intercepted by a quartz cesium-cesium oxide photocell with plane window, the current from which was amplified by a modified Barth<sup>9</sup> circuit, using an FP54 tube, the batteries being continuously charged with a trickle-charger. The radiation transmitted by the cell was intercepted by a potassium hydride cell with glass envelope, the current being read directly with a sensitive galvanometer.

The pressures were measured either directly on a manometer or by means of a McLeod gage of low sensitivity. When both biacetyl and acetone were used together, they were admitted to a large mixing chamber and condensed with liquid air. After vaporization sufficient time was allowed for complete mixing, and then a portion of the mixture was expanded into the cell.

In all instances the fluorescent radiation was partially limited to certain spectral regions by the use either of a Wratten 8 or a Wratten 25 filter. The fluorescence of biacetyl consists of three bands<sup>2,6</sup> with maxima at 5120, 5580 and 6100 Å. These filters transmit the following percentages of incident radiation at these wave lengths, respectively: Wratten 8, 73, 86, and 89%; Wratten 25, 0, 0, and 75%. Thus the use of the Wratten 25 filter permits a study of the 6100 Å. band alone. The Wratten 8 filter served mainly to eliminate scattered light.

## III. Results

No visible fluorescence could be excited in pure biacetyl by the mercury lines at either 3130 or 2537 Å.

It does not seem useful to give all of the numerical data in detail. The absorption coefficient for biacetyl, using the 3650 Å. radiation obtained as described above, was first determined. Beer's law was found to be obeyed within experimental error. At 29° the transmitted light is given by the expression

$$I_{\text{trans.}} = I_0 \exp. (-0.00040dP) \quad (10)$$

where  $d$  is the thickness in centimeters and  $P$  is the pressure in millimeters.  $I_0$  is the intensity when the biacetyl is condensed with liquid air. Almy and his co-workers give a coefficient of 0.00042 without specifying the temperature.<sup>4</sup> At other temperatures (from 15 to 60°), the same law seems to be obeyed quite closely providing the change in density with temperature is taken into account. Thus if the pressure is expressed in millimeters, the coefficient may be written as  $0.121/T$  where  $T$  is the absolute temperature.

Table I presents examples of data obtained at 29° through a Wratten 8 filter. For the first ten points the incident intensity was practically constant and the biacetyl pressure varied. The last

(9) Penick, *Rev. Sci. Instruments*, **6**, 115 (1935).

TABLE I  
FLUORESCENCE OF BIACETYL AT 29° ( $\lambda = 3650 \text{ \AA.}$ )

Pressure mm.	Transmitted in. intensity (arbitrary units) $I_i$	In. intensity fluorescence + scattered light (arbitrary units) $I_f + I_s$	Fluorescent intensity (arbitrary units) $I_f$	Absorbed in. intensity (arbitrary units) $I_a$	$I_f/I_a \times 2.35 \times 10^{-3}$
0	49.2	1.0	0	0	...
52.0	43.2	55.9	54.9	4.49	0.0287
41.5	43.2	43.9	43.0	3.55	.0286
33.2	44.2	32.7	31.7	2.88	.0258
23.5	44.8	20.8	19.9	2.05	.0228
13.0	44.9	8.4	7.5	1.12	.0157
17.5	44.1	13.2	12.3	1.49	.0183
28.7	43.1	26.8	25.9	2.41	.0252
39.5	42.0	39.5	38.6	3.28	.0277
48.0	41.7	49.0	48.1	3.98	.0283
48.0	33.1	39.4	38.7	3.16	.0287
48.0	21.5	25.7	25.2	2.05	.0288
48.0	14.9	17.5	17.2	1.42	.0284
48.0	6.0	7.0	6.9	0.573	.0283

five points were obtained at constant pressure but with variable  $I_0$ .

The figures in the last column are based on the quantum efficiency for fluorescence of 0.029 obtained at relatively high pressures by Almy and his co-workers.<sup>6</sup> The factor  $2.35 \times 10^{-3}$  is em-

pirically chosen to make the quantum efficiency have a maximum value of 0.029.

Two conclusions relative to the data at 29° seem to be permitted from the data in Table I: (a) the fluorescence efficiency is not constant and independent of pressure but apparently decreases at low pressures; (b) at constant pressure the fluorescence efficiency is independent of the incident intensity even though the latter was varied nearly sevenfold.

The bulk of the data are summarized in Figs. 2 to 4 inclusive. In Fig. 2 it is seen that  $I_f/I_a$  increases with pressure at first rapidly and then more slowly, finally becoming practically constant. Moreover, by the use of color filters (Fig. 2) it is shown that there is no significant change of distribution of intensity among the wave lengths as a function of pressure. In Fig. 3 it is seen that  $I_f/I_a$  decreases with increase in temperature, although the general form of variation with pressure is maintained.

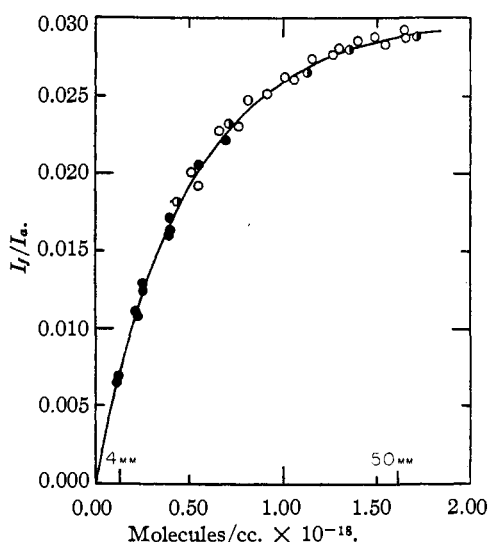

Fig. 2.—Fluorescent efficiency at 29° as a function of pressure of biacetyl: (1)  $\circ$ , fluorescent radiation passed through a Wratten 8 filter. Incident light monochromated through use of Corning Violet Ultra glass and Cupric Ammonium Sulfate filter. (2)  $\bullet$ , fluorescence as in 1. Incident radiation monochromated by use of Violet Ultra glass alone. (3)  $\circ$ , fluorescence passed through Wratten 25 filter. Incident light as in 2. The curve is a graphical representation of equation (23).

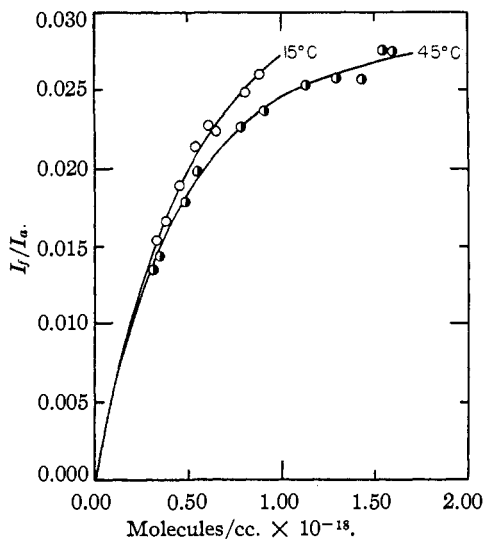

Fig. 3.—Effect of temperature on the fluorescent efficiency of biacetyl. Both curves are obtained from equation (23).

The data for Fig. 2 could not be carried to pressures higher than the vapor pressure of biacetyl. The curve might pass through a maximum if higher pressures could be attained. To afford a partial test of this point acetone was mixed with the biacetyl, the data being given in Fig. 4. Acetone was chosen because the fluorescence of this substance has been attributed to biacetyl and because resonance between the two molecules might be better than if some other foreign molecules

were used. Moreover, acetone is transparent at 3650 Å.

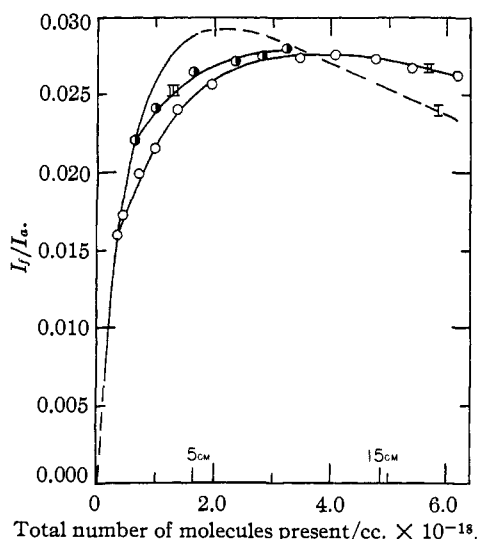

Fig. 4.—Effect of acetone on the fluorescent efficiency of biacetyl at 29°: I. No acetone was present. The broken lines are an extrapolation based on equation (24). II. Pressure of biacetyl is 11.5 mm. Pressure of acetone varies between 0 and 180 mm. III. Pressure of biacetyl is 20.0 mm. Pressure of acetone varies between 0 and 80 mm. Curves II and III are obtained from equation (22).

The addition of acetone to biacetyl increases the value of  $I_f/I_a$  but not quite to the same value that this ratio would have if the biacetyl were present alone at the same total pressure. With sufficient acetone the ratio passes through a maximum as it would probably also do if higher biacetyl pressures could have been used.

#### IV. Discussion

The trend of the  $I_f/I_a$  ratios with increasing pressure of biacetyl or with constant pressure of biacetyl and increasing pressure of added acetone indicates that collisions are effective, in some way, in enhancing the fluorescence. This is just the opposite of the effect one would expect from a Stern-Volmer mechanism where collisions are assumed to play only a deactivating role. This effect, whatever its cause, undoubtedly is accompanied by some collisional deactivation.

Various explanations of the data might be advanced, but most of them would rest on uncertain or completely illogical hypotheses. Thus there seems to be no *a priori* reason for believing that one vibration level of a stable upper state should have a much higher transition probability for fluorescence than other levels or at least than

other adjacent levels. The spectrum of the fluorescence at various pressures and from various sources<sup>2,3,4</sup> indicates that transitions must occur solely or almost solely from one vibration level of the upper state, probably the lowest. Evidence presented above using color filters offers further substantiation of this point.

The most plausible explanation of the data is based on the following assumptions: (1) at 3650 Å. an upper state,  $B^0$ , is formed upon absorption which may either dissociate or undergo a transition to another state,  $B^1$ . This transition is reversible. (2)  $B^1$  may dissociate, but the inclusion of this process is unnecessary for the explanation of the data.  $B^1$  may, however, be transformed into a third state,  $B^2$ , by collisions. (3)  $B^2$  may fluoresce, may be deactivated by collision, or may be converted back into  $B^1$  by collision.

The mechanism may be stated in the equations

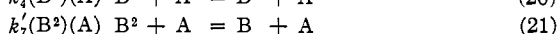
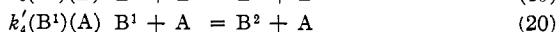
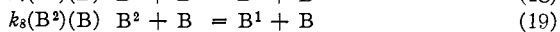
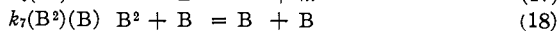
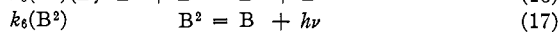
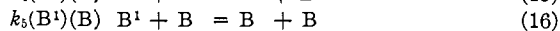
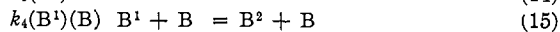
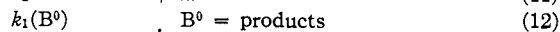

A represents a molecule of acetone. States  $B^0$  and  $B^1$  may fluoresce, but rates of fluorescent decay must be small compared to those of other reactions they undergo in this pressure range. This statement is strongly supported by the character of the spectrum. Other reactions involving acetone molecules can be shown to be unimportant. Equations (16), (18), and (21) could be replaced by other second order steps (for example, induced predissociation) which would lead to quenching.

The small amount of auto-quenching found by Almy and his co-workers<sup>4,5,6,7</sup> and also in this work indicates that  $k_8$  must be small compared to  $k_4$ . The contribution of equation (19) will probably be small due to the Boltzmann factor.

With the usual assumptions regarding the steady state it is found that

$$I_a/I_f = 1/Q = \frac{k_1 k_3}{k_2(k_4(B) + k'_4(A))} + \frac{(k_1 + k_2)}{k_2} + \frac{k_1 k_3 (k_7(B) + k'_7(A))}{k_2 k_6 (k_4(B) + k'_4(A))} + \frac{(k_1 + k_2)(k_7(B) + k'_7(A))}{k_2 k_6} \quad (22)$$

While  $k_4$  may vary slightly with temperature, the only constants which might be expected to vary appreciably with temperature are  $k_7$  and  $k'_7$ .

In order to eliminate the arbitrary units used in measuring  $I_a$  and  $I_f$ , it is assumed that  $I_f/I_a$  at high pressures is 0.029 as found by Almy and co-workers.<sup>6,7</sup> The following empirical equation is found to fit the data between 15 and 60° for pure biacetyl

$$I_a/I_f = 15.2 \cdot 10^{18}/(B) + 2.9 + 125 \exp.(-1200/RT) + 24 \cdot 10^{-18} (B) \exp.(-1200/RT) \quad (23)$$

where (B) is in molecules per cubic centimeter. The smooth curves in Figs. 2 and 3 are obtained from equation (23) since (A) = 0.

By comparing the empirical constants of equation (23) with those in the theoretical equation (22) and converting to the more customary unit of moles per cubic centimeter we find

$$k_1/k_2 = 2 \quad (24)$$

$$k_4/k_3 = 8 \cdot 10^4 \text{ cc./mole} \quad (25)$$

$$k_7/k_6 = 5 \cdot 10^9 \exp.(-1200/RT) \text{ cc./mole} \quad (26)$$

Nothing definite can be said concerning the orders of magnitude of  $k_1$  and  $k_2$ . Since  $k_1/k_2$  should increase with frequency, the absence of fluorescence at 3130 and 2537 Å. is understandable. Also nothing can be said definitely concerning the magnitude of  $k_4$  except that it might be expected to be about  $10^{13}$ , a value found for most bimolecular reactions. If this value is assumed,  $k_3$  is about  $10^8$ , and the slow step in the fluorescence mechanism is equation (17). Almy and co-workers find the lifetime of the fluorescence to be about  $10^{-3}$  second. If the responsibility for this long lifetime is placed on (17) (and this assumption cannot be further substantiated),  $k_6$  is about  $10^8$ . Then  $k_7$  is found to be about  $5 \cdot 10^9 \exp.(-E/RT)$ , leading to an effective cross section for quenching of  $0.0025 \text{ Å.}^2$  or to a transmission coefficient<sup>8</sup> of about  $10^{-3}$ . Thus the small constant for quenching agrees with the results of Almy and co-workers at 4358 Å.

It should be pointed out that a normal rate of quenching would be obtained if  $k_6$  were about  $10^8$ .

If the lifetime of  $B^2$  is really as short as  $10^{-8}$  second, the slow rate of decay of fluorescence will have to be explained by assuming that one of the states  $B^0$  or  $B^1$  (preferably  $B^1$ ) is metastable with respect to all processes which tend to remove molecules from it.

Turning to the effect of adding acetone to the biacetyl, it is found that the results may be made to fit equation (22) if  $k'_4 = 0.48 k_4$  and  $k'_7 = 0.53 k_7$ . Curves II and III in Fig. 4 are based on these values. Thus acetone is about half as effective as biacetyl either in quenching excited biacetyl to the ground state or in causing transitions from one excited state to another.

### Summary

1. The proper use of the intensity of radiation absorbed for fluorescence experiments is discussed briefly.
2. Biacetyl emits no measurable fluorescence when irradiated by 3130 and 2537 Å.
3. The fluorescence of biacetyl as excited by radiation of wave length 3650 Å. has been studied as a function of pressure (4 to 50 mm.), temperature (15 to 60°), and intensity.
4. As the pressure of biacetyl increases, the quantum efficiency of fluorescence increases, indicating the apparent reverse of quenching. The fluorescence efficiency is independent of incident intensity.
5. The addition of acetone produces the same general effect of enhancing the fluorescence efficiency, although very high pressures of acetone lead to some apparent quenching.
6. The effect of temperature indicates an activation energy of about 1200 calories for the quenching process.
7. It is possible to explain the results by assuming that the state formed by absorption cannot fluoresce but is changed to other states which can fluoresce through the agency of collisions. At least three upper states seem to be involved.

ROCHESTER, NEW YORK      RECEIVED JANUARY 19, 1940